

Uchwyty do transportu blach w pionie model ULC

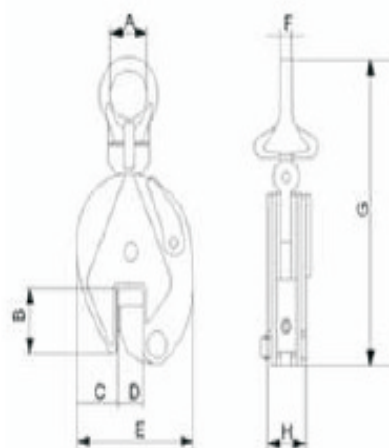

MODEL	ULC-10	ULC-20	ULC-30
Indeks magazynowy	981200411198120041129812004113		
Dopuszczalne Obciążenie Robocze [kg]	1000	2000	3000
Zakres chwytania blach [mm]	0 – 20	0 – 25	0 - 30
Wymiary [mm]	A	48	68
	B	63	74
	C	42	54
	D	28	34
	E	137	163
	F	12	18
	G	294	370
	H	54	58
Masa uchwyty [kg]	5	8	15

mgr Arkadiusz Perlik
 RYWAL-RHC Sp. z o.o.
 tel. +48 56 66 93 839
 fax. +48 56 66 93 805
 GSM +48 693 168 349
 arkadiusz.perlik@rywal.com.pl
 suwnice@rywal.com.pl